

## Model RP8L

## Reduced Pressure Principle 2-1/2" to 8"

### FEATURES

- Extremely low head loss
- All internal parts serviceable in-line
- Ductile iron bodies
- 15-20 mil fusion epoxy coating
- Designed to insure long, trouble-free operation

### CHARACTERISTICS

Max. Working Pressure	175 PSI
Hydrostatic Test Press.	350 PSI
Temperature Range	32° F to 140° F

### SPECIFICATIONS

Reduced pressure backflow preventer assemblies include two independently operating check valves with an automatically operating, mechanically independent, hydraulically dependent pressure differential relief valve located between the two check valves.

During, and at the cessation of normal flow, the pressure in the zone between the two check valves is at least 2 PSI less than the upstream pressure. With no flow from the upstream side when the flow from the supply side drops to 2 PSI above the zone pressure, the relief valve will discharge water to maintain 2 PSI below the supply pressure.

When the pressure on the upstream side of the first check valves drops below 2 PSI above the zone pressure the relief valve is open. Under a backflow condition, when upstream pressure is 2 PSI or more, the relief valve discharges water, and the pressure in the zone is at least 1/2 PSI below upstream pressure.

### APPLICATION

Reduced pressure backflow preventers are used to protect against contamination from hazardous (toxic) fluids in potable water supply systems servicing: Office buildings, industrial plants, hospitals, apartment complexes, shopping malls, private homes, laundries, shipyards, mortuaries, irrigation systems, steam boilers, chemical plants and many others.

### INSTALLATION

A Reduced Pressure Backflow Preventer should be installed with a suggested minimum clearance of 12" between port and floor or grade. It must be installed so discharge will not be objectionable and can be positively drained away. Installation should promote easy maintenance, testing, and freeze protection. Thermal water expansion and/or water hammer downstream can cause excessive pressure, which may cause damage to the system and assembly.

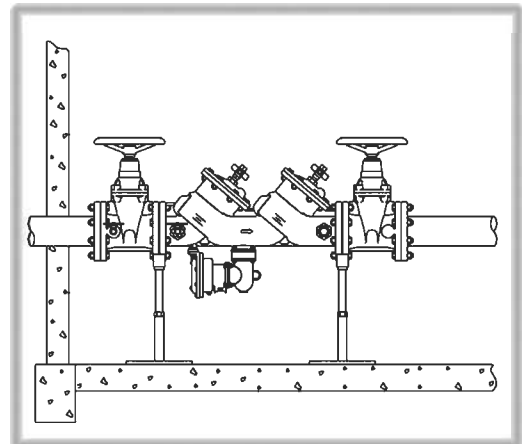

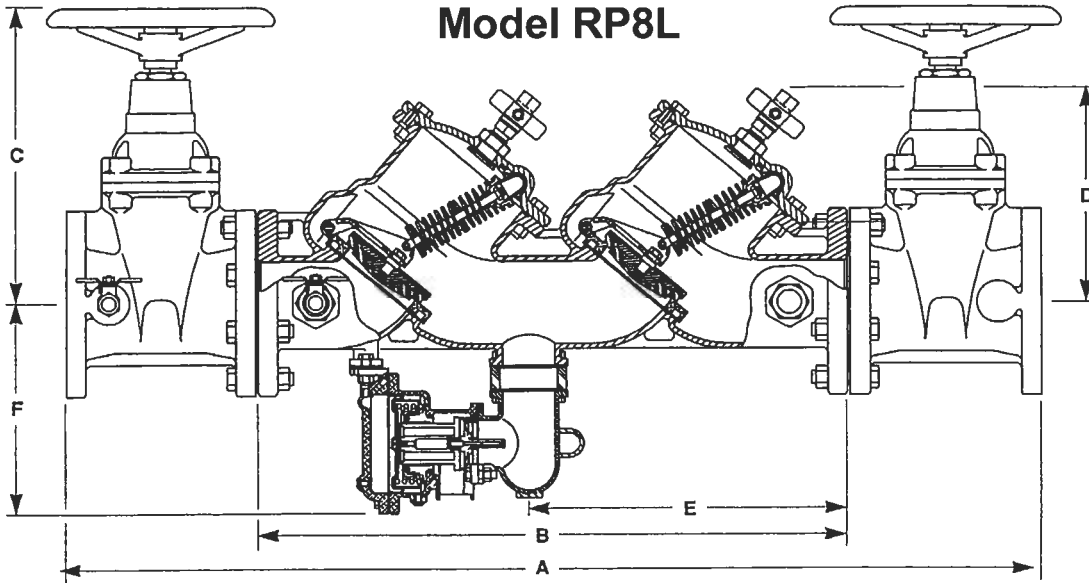

Top View

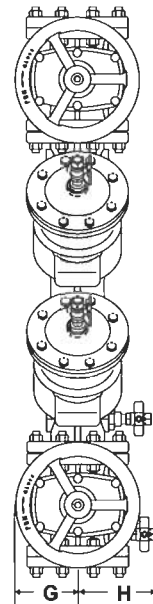

## DIMENSIONS & WEIGHTS

SIZE	U.S. - Inches								Net Lbs. NRS	Net Lbs. OS&Y
	A	B	C	D	E	F	G	H		
2½"	40¾	25½	12 <sup>5</sup> / <sub>8</sub>	10¼	12 <sup>7</sup> / <sub>8</sub>	10	4½	7 <sup>1</sup> / <sub>8</sub>	219	223
3"	41 <sup>7</sup> / <sub>8</sub>	25 <sup>5</sup> / <sub>8</sub>	12 <sup>7</sup> / <sub>8</sub>	10¼	13	10	4½	7 <sup>3</sup> / <sub>8</sub>	231	233
4"	46¼	28	14 <sup>3</sup> / <sub>8</sub>	10¼	15 <sup>1</sup> / <sub>8</sub>	10 <sup>1</sup> / <sub>8</sub>	5½	8 <sup>1</sup> / <sub>8</sub>	317	334
6"	56	34¾	18 <sup>7</sup> / <sub>8</sub>	13	20¾	11 <sup>1</sup> / <sub>8</sub>	6½	9 <sup>7</sup> / <sub>8</sub>	481	516
8"	65	41¾	23½	15 <sup>5</sup> / <sub>8</sub>	26 <sup>7</sup> / <sub>8</sub>	12¼	7	11 <sup>1</sup> / <sub>8</sub>	734	796

Note: Dimensions are nominal. Allowances must be made for normal manufacturing tolerances.

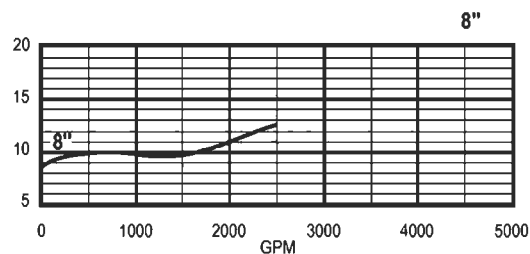
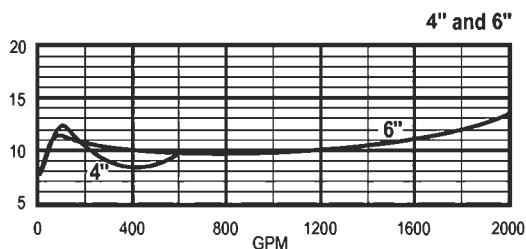
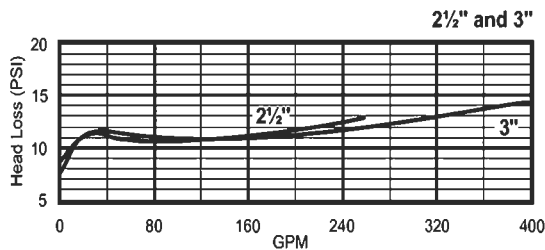

## MATERIALS

End detail

Main valve body

Main valve trim

Relief valve body and trim

Elastomers

Springs

Shut-offs

2-1/2" - 10"

Flanged ANSI B16.1

Ductile iron 65-45-12  
fusion epoxy coated  
internal and external  
Bronze

Bronze

EPDM

Diaphragms: Nitrile,  
fabric reinforced

Stainless steel

Non-rising stem,  
resilient seated gates