

Series 820 Reduced Pressure Assembly 1/4", 3/8" & 3/4"

Typical Specifications

The reduced pressure backflow preventer shall consist of two independently operating check valves and one hydraulically dependent differential relief valve all accessible from top of the valve. The assembly shall automatically reduce the pressure in the "zone" between the check valves to at least 5 PSI lower than inlet pressure. Should the differential between the upstream and the zone of the unit drop to 2 PSI, the differential relief valve shall open and maintain the proper differential.

Pressure - Temperature

The assembly shall be rated to 150 PSI water working pressure and water temperature range from 32°F to 140°F

Features

- Ultimate mechanical protection of carbonated beverage dispensers and other point-of-use potable water applications against hazards of cross connection contamination.
- Modular check and relief valve for ease of maintenance.
- Simple Service procedures. All check and relief valve internal parts serviceable in-line, from the top of the valve.

Operation

In a flow condition the check valves are open with the pressure between the checks, called the zone, being maintained at least 5.0 PSI lower than the inlet pressure and the relief valve is maintained closed.

Should abnormal conditions arise under no flow or reversal of flow with a failed second check, the differential relief valve will open and discharge to maintain the zone at least 2 psi lower than the supply.

When normal flow resumes the zone's differential pressure will resume and the relief valve will close.

Typical Applications

Reduced Pressure assemblies are used to protect against high hazard (toxic) fluids in beverage dispensors, industrial plants, hospitals, dental offices, morgues, mortuaries, and chemical plants. They are also used in irrigation systems, boiler feed and other point-of-use installations requiring maximum protection and small pipe size.



Installation

Reduced Pressure assemblies must be installed where discharge will not be objectionable and can be positively drained away. Discharge from the relief valve will occur and FEBCO is not liable for damage caused by relief valve discharge. The Model 820 should be installed where easily accessible for testing and maintenance and must be protected from freezing. Thermal water expansion and/or water hammer downstream of the backflow preventer can cause excessive pressure. Excessive pressure situations should be eliminated to avoid possible damage to the system and assembly.

Refer to local codes for specific installation requirements. Some codes may prohibit vertical installation.

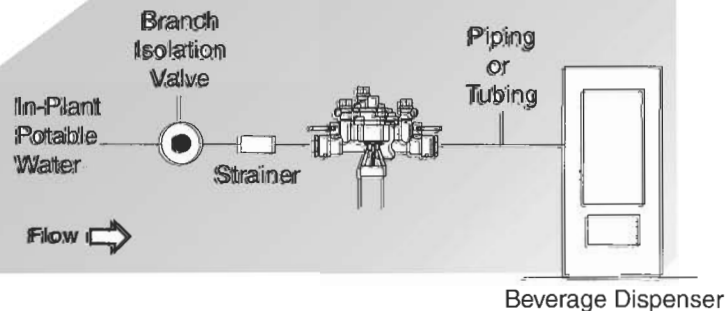

SERIES 820

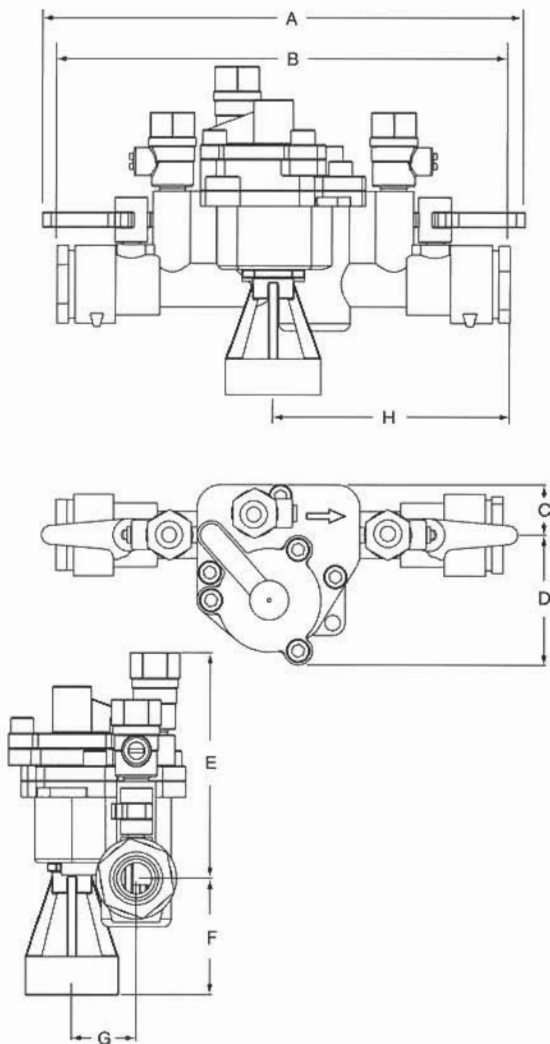

Dimensions and Weights

| U.S. - INCHES | | | | | | | | | WT. |
|---------------|-------------------------------|-------------------------------|-------------------------------|---|-------------------------------|-------------------------------|---|-------------------------------|--------|
| Size | A | B | C | D | E | F | G | H | (lbs.) |
| ALL | 7 ³ / ₅ | 7 ¹ / ₆ | 4 ¹ / ₅ | 2 | 3 ³ / ₅ | 1 ⁵ / ₆ | 1 | 3 ³ / ₄ | 3.75 |

Weights are approximate. Dimensions shown are nominal, allowances must be made for normal manufacturing tolerances.

Model 820 (1/4", 3/8", 1/2") Flow Curve

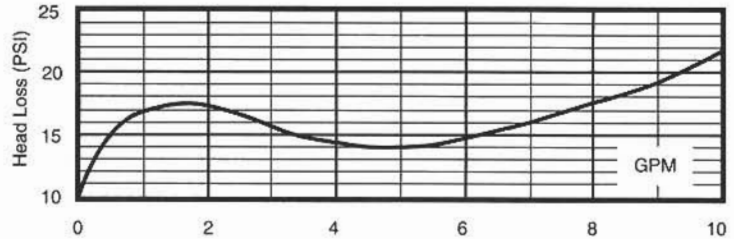

Agency Compliance

- ASSE Listed (Std. 1013)

Characteristics and Materials

| | |
|---------------------------|--|
| Maximum Working Pressure | 150 PSI |
| Hydrostatic Test Pressure | 300 PSI |
| Temperature Range | 32°F to 140°F |
| Fluid | Water |
| End Detail | Threaded ANSI B1.20.1 |
| Valve Body | Bronze |
| Valve Cover | Bronze |
| Elastomers | Silicone |
| | Diaphragms: Silicone, Fabric Reinforced |
| Springs | Stainless Steel |

- 1 Body
- 2 1st Check Module
- 3 2nd Check Module
- 4 Relief Valve Module
- 12 Ball Valve Stem
- 13 Ball Seal
- 14 Ball
- 15 Tailpiece
- 16 O-Ring
- 17 Cover
- 30 Relief Valve Cover
- 31 O-Ring
- 32 Cap Screw
- 33 Cover Seal
- 34 Testcock
- 35 Handle
- 36 Airgap Drain
- 37 O-Ring

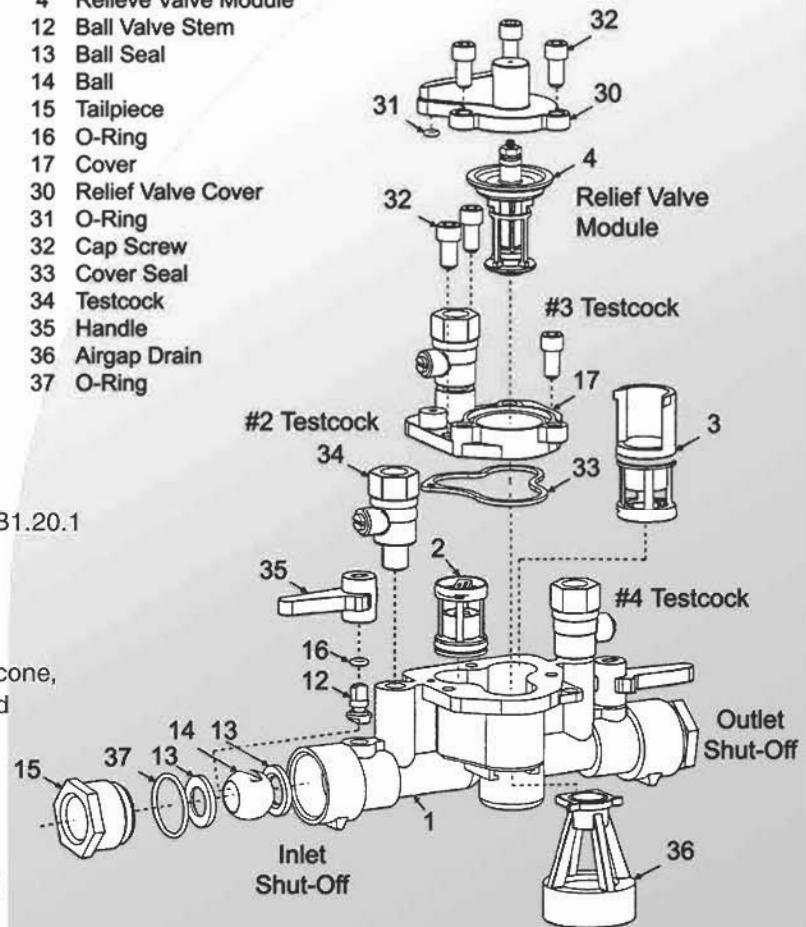

American Backflow Specialties

www.americanbackflow.com

(800) 66-BKFLO

(619) 527-2525

Fax: (619) 527-2527