

Model 856 (2-1/2"-10") Double Check Detector Assembly

Characteristics

Physical Properties

Max. Working Pressure	175 PSI (1200 KPa)
Hydrostatic Test Press.	350 PSI (2400 KPa)
Temperature Range	32° F to 140° F (0° C to 60° C)
End Connections	Flanged ANSI B16.1 Class 125

Agency Compliance

- ASSE Listed (Std. 1048) - 2 1/2" - 8", 10" (Horizontal)
- ANSI/AWWA Conformance (C510-89) - 2 1/2" - 8", 10" (Horizontal)
- CAN/CSA (B64.5) - 2 1/2" - 8"
- FM - 2 1/2" - 8"
- UL* - 2 1/2" - 8"
- cUL* - 2 1/2" - 8"
- FCCC & HR - 2 1/2" - 8"

* At this time UL does not make a distinction between vertical and horizontal installations.

Specifications

Double check detector assemblies include two independently acting approved check valves mounted between two tightly closing resilient seated shutoff valves, and the necessary four resilient seated test cocks.

Each check valve is internally loaded and is drip-tight in the normal flow direction with inlet pressure of at least 1 PSI and the outlet under atmospheric pressure. Each check valve will not leak in a direction reverse to the normal flow under all conditions of a pressure differential.

All double check detector assemblies are constructed so that all internal parts, including seat rings, can be serviced with common tools without removing the device from the line.

Applications

Double check detector assemblies are used to prevent backflow of objectionable (non-toxic) pollutants. They may be installed under continuous pressure service and may be subjected to backpressure.

Double check detector assemblies are primarily used on fireline sprinkler systems when it is necessary to monitor unauthorized use of water.

Installation

Double check detector assemblies should be installed with adequate clearance and easy accessibility for testing and maintenance and must be protected from freezing. The assembly may be installed horizontally or vertically with flow up. Larger sizes should be installed horizontally for ease of service. Thermal water expansion and/or water hammer downstream of the assembly can cause excessive pressure, which should be eliminated to avoid possible damage to the system and assembly.

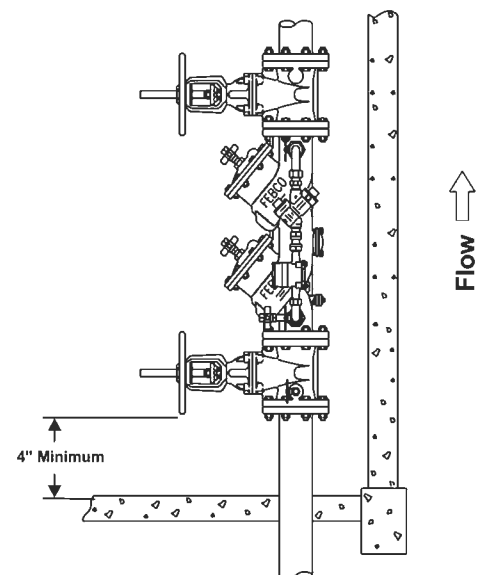

MODEL 856
VERTICAL INSTALLATION

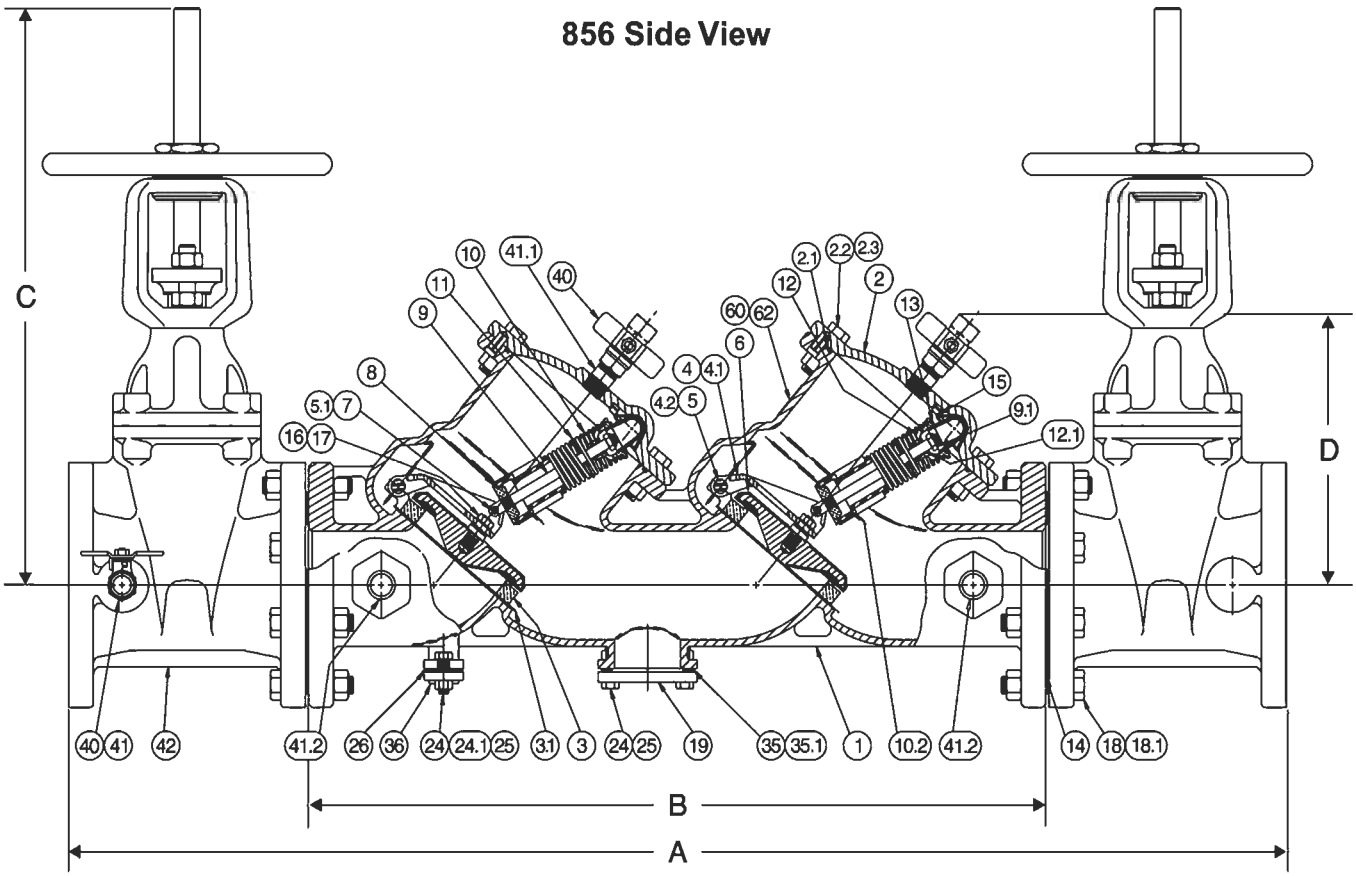

Dimensions and Weights
U.S. Inches (mm)

SIZE	A	B	C**	D	E	F	G	NETWT. Lbs. OS&Y
2½"	40¾	25½	16¾	10	13¾	7⅛	4½	218
3"	41⅞	25⅝	22¼	10	13¾	7¾	4½	228
4"	46¼	28	23¼	10⅞	14	8⅞	5½	327
6"	56	34¾	30⅞	12¾	15	9⅞	6½	509
8"	65	41¾	37¾	15⅝	15¾	11⅞	7	789
10"	72⅝	46¾	48	15⅝	15¾	12¾	9	909

856 Top View with 3/4" Bypass

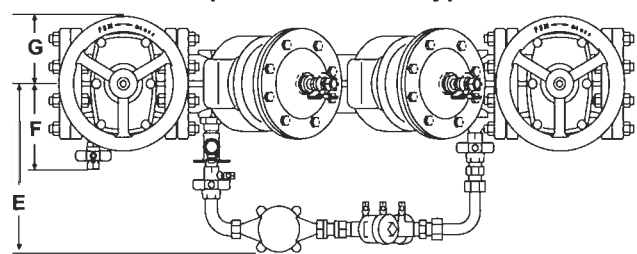

Note: Dimensions are nominal. Allowances must be made for normal manufacturing tolerances.

Model 856 Flow Curves

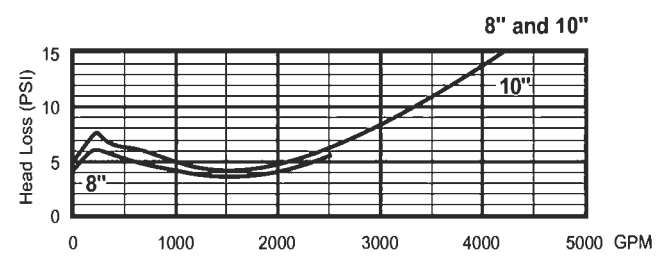
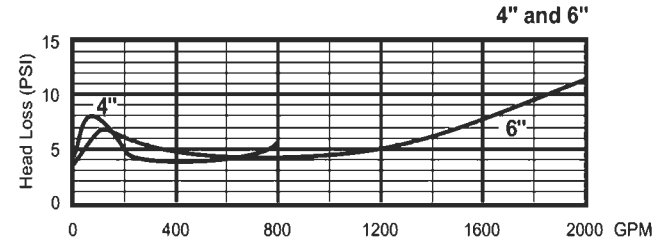
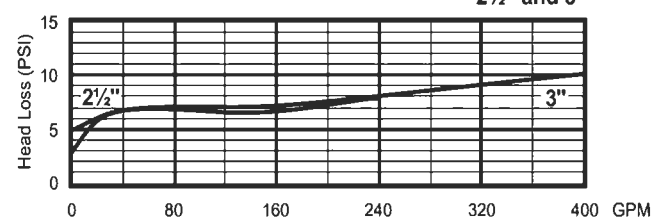

MODEL 856 REPAIR KITS LIST (850, 876, 870 Also Included)

KIT DESCRIPTION		2-1/2"	3"	4"	6"	8"	10"
Check Replacement Kit (items 2.1, 3, 3.1, 3.2, 3.4, 4, 4.1, 4.2, 5, 5.1, 6, 7, 8, 9, 9.1, 10, 11, 12, 12.1, 13, 15, 16, 17)	850 870(V) 856 876(V)	905-527 905-528 905-529 905-530	905-527 905-528 905-529 905-530	905-534 905-534 905-536 905-536	905-537 905-537 905-538 905-538	905-539 905-539 905-541 905-541	905-539 905-540 905-541 905-542
856/876 DCDA Inlet Spring Module (items 5.1, 7, 8, 9, 9.1, 10, 10.2, 11, 12, 12.1) (8" - item 10.3)		905-147	905-147	905-148	905-149	905-150	905-150 (856) 905-151 (876)
856/876 DCDA Outlet Spring Module (items 5.1, 7, 8, 9, 9.1, 10, 10.2, 10.3, 11, 12, 12.1) (8" - item 10.3)		905-147	905-147	905-148	905-149	905-150	905-150 (856) 905-151 (876)
850/856 Disc Assembly (items 6, 16, 17) (10" - item 6 only)		905-182	905-182	905-153	905-154	905-155	905-155
Seat Ring / Arm Assembly (items 3, 3.1, 3.2, 3.4, 4, 4.1, 4.2, 5)		905-157	905-157	905-158	905-159	905-160	905-160 (850/856) 905-161 (870/876)
850/856 Rubber Kit (items 2.1, 3.1, 6, 15, 26, 35, 35.1, 45, 45.1)		905-249	905-249	905-163	905-164	905-165	905-165
850/856 Cover Assembly both checks 876(V) Inlet Check only (items 2, 2.1, 15)		905-167	905-167	905-168	905-169	905-170	905-170 (850/856) 905-171 (876V)
Bulkhead Fittings Assembly Cover (items 43.1, 45.1, 46.1, 47.1)		905-275	905-275	905-275	-	-	-
Bulkhead Fittings Assembly Cover (items 43, 45, 46, 47)		905-276	905-276	905-276	-	-	-
Bulkhead Fittings Assembly Body & Cover (items 43, 45, 46, 47)		905-277*	905-277*	905-277*	905-277	905-277	905-277
Bulkhead Plug Assembly 2nd Check Cover (N & V Units) Early Prod. (items 44, 45.1, 46.1, 47.1)		905-278	905-278	905-278	-	-	-
Bulkhead Plug Assembly 2nd Check Cover (N & V Units) Early Prod. (items 44, 45, 46, 47)		-	-	-	905-279	905-279	905-279

* Models 856 and 876 only. Some of the above items are only available as part of a repair kit.



INDIVIDUAL PARTS

ITEM	DESCRIPTION	MATERIALS	ITEM	DESCRIPTION	MATERIALS	ITEM	DESCRIPTION	MATERIALS
1	Body	A536 GR 65-45-12	8	Lwr Spring Retnr	B584 Alloy C83600	24	Bolt	Plated Steel
2	Cover	A536 GR 65-45-12	9	Spring Stem	304 SS	24.1	Washer	Plated Steel
2.1	O-Ring	EPDM ASTM D2000	9.1	ELastic Stop Nut	18-8 SS	25	Bolt	Plated Steel
2.2	Cap Screw	Plated Steel	10	Spring	A313 Type 631 SS	26	Gasket	EPDM ASTM D2000
2.3	Hex Nut	Plated Steel	10.2	Spring Shim	Acetal Resin	35	O-Ring	EPDM ASTM D2000
3	Seat Ring	B584 Alloy C83600	11	Spring Guide	B130 Alloy C22000	35.1	Back-Up Ring	Acetal Resin
3.1	Gasket	EPDM ASTM D2000	12	Upr Spring Retnr	B584 Alloy C83600	36	Cover	B584 Alloy C83600
4	Arm	B584 Alloy C83600	12.1	Bushing-Spr. Stem	Acetal Resin	40	Ball Valve	B584 Alloy C84400
4.1	Bushing-Swing Pin	Acetal Resin	13	Pivot Bearing	B585 Alloy C83600	41	Nipple	Brass
4.2	Swing Pin	304 SS	14	Flange Gasket	Rubber/Fabric	41.1	Nipple	Brass
5	Retaining Clip	302 SS	15	Bearing Socket	Acetal Resin	41.2	Nipple	Brass
5.1	Retaining Clip	302 SS	16	Hex Jam Nut	18-8 SS	42	Gate Valve (OS&Y)	AWWA C509
6	Check Disk Assy	EPDM Coated GR, 45 Ductile Iron with type 304 SS stem	17	Washer	302 SS	60	Name Plate	B36 Alloy C26000
7	Load Pin	304 SS	18	Flange Nut	Plated Steel	62	Drive Screws	SS
			18.1	Flange Nut	Plated Steel	70	Clamp	AWWA C606 (10" Only, Not Shown Above)
			19	Cover	A36 Steel Epoxy Coat			