

BACKFLOW PREVENTION

Model 870 / 870V (2-1/2"-10") Double Check Assembly

Physical Properties

Max. Working Pressure	175 PSI (1200 KPa)
Hydrostatic Test Press.	350 PSI (2400 KPa)
Temperature Range	32° F to 140° F (0° C to 60° C)
End Connections	Flanged ANSI B16.1 Class 125

Materials

Main Valve Body	Ductile iron Grade 65-45-12
Coating	Fusion epoxy coated internal and external AWWA C550-90
Shut Off Valves	NRS and OS&Y resilient wedge gate valves AWWA C509
Trim	Bronze
Elastomer Discs	EPDM
Spring	Stainless steel

Applications

Double check valve backflow prevention assemblies are used to prevent backflow of objectionable (non-toxic) pollutants. They may be installed under continuous pressure service and may be subjected to backpressure.

Double checks can be used in sprinkler systems and fire systems without chemical additives, protection of industrial plants, industrial in-plant plumbing systems and other systems requiring protection.

Specifications

Double check backflow preventer assemblies shall include two independently acting approved check valves mounted between two tightly closing resilient seated shutoff valves, and the necessary four resilient seated test cocks.

Each check valve is internally loaded and is drip-tight in the normal flow direction with inlet pressure of at least 1 PSI and the outlet under atmospheric pressure. Each check valve will not leak in a direction reverse to the normal flow under all conditions of a pressure differential.



All double check valve assemblies are constructed so that all internal parts, including seat rings, can be serviced with common tools without removing the device from the line.

Installation

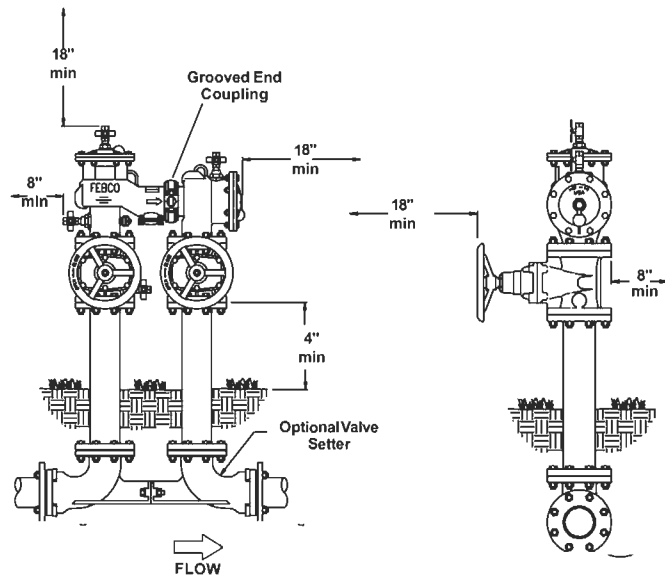

Standard orientation 870V

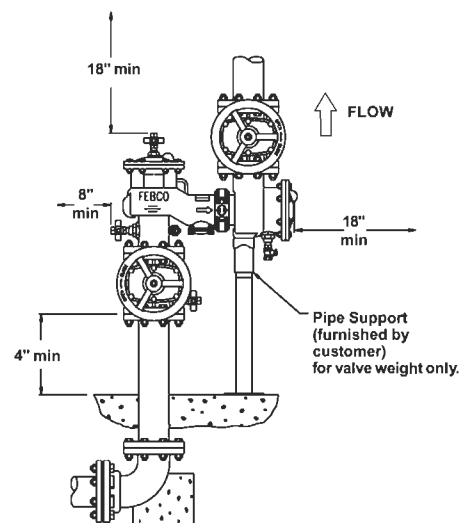

Vertical orientation 870V

Compliance

Model 870/870V

- ASSE (Std 1015)
- ANSI/AWWA (C510-89)
- CAN/CSA (B64.5)
- FM*
- UL*
- cUL
- FCCC & HR
- Less gate not FM approved.
Less gate not UL listed without
UL listed gated valves.

Options

- Valve Setter with MJ x FL or FL x FL ends
- UL/FM OS&Y RW Gate Valves
- Relief Valve Air Gap Drain Funnel
- Wye Strainer

Flow Orientation

Standard orientation is inlet flow vertical up, outlet flow vertical down.
Vertical orientation is inlet and outlet flow vertical up.

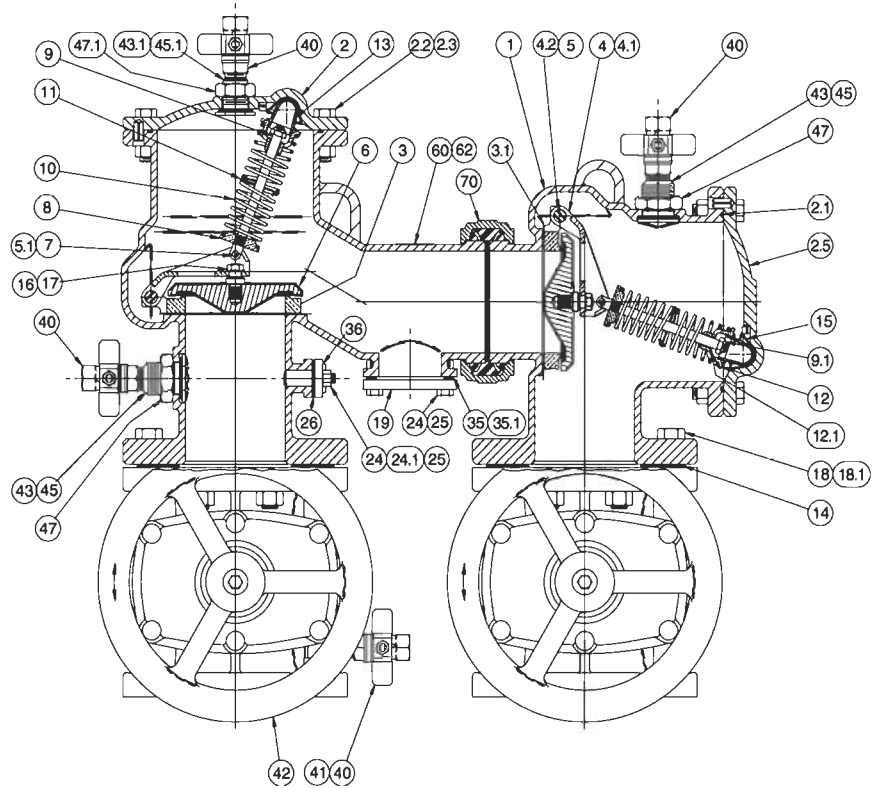

Model 870/870V Standard Orientation

Note: The Model 870V is shipped in the standard (N-Shape) orientation as shown below. Model 870 does not include grooved end coupling.

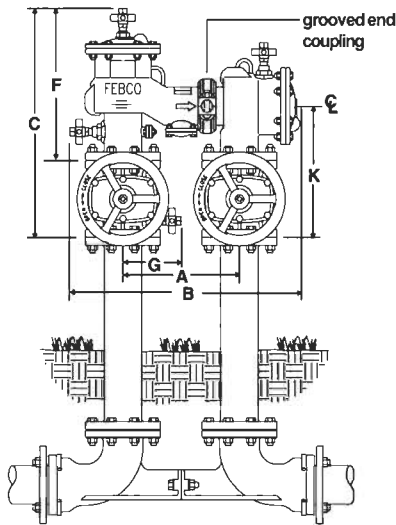

Model 870V Vertical Orientation

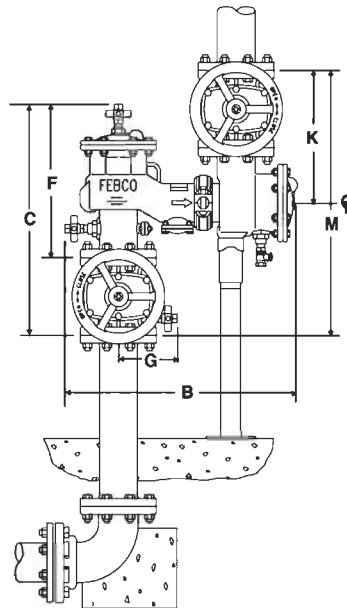

NRS Side View

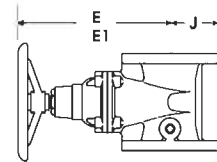

Dimensions

(U.S. Inches)

SIZE	A	B	C	E	E1	OS&Y Full	F	G	J	K	M	Net NRS (lbs.)	Net OS&Y (lbs.)
2 1/2"	12 1/2	25 3/4	24 1/4	12 5/8	16 3/8	16 5/8	6 1/4	3 1/2	13 5/8	27 1/4	190	200	
3"	12 1/2	25 3/4	24 3/4	12 7/8	22 1/4	16 5/8	6 1/4	3 3/4	14 1/8	28 1/4	260	270	
4"	14	27 7/8	26 3/4	14 3/8	23 1/4	17 3/4	7	4 1/2	15 1/2	31	300	320	
6"	16	32 1/4	32 1/4	18 7/8	30 1/8	21 4/7	8	5 1/2	18 5/8	37 1/4	460	500	
8"	18 1/2	37 1/2	36 3/8	23 1/2	37 3/4	24 7/8	9 1/4	6 3/4	20 3/4	41 1/2	780	840	
10"	21	42 1/2	40 3/4	27 1/2	48	27 1/2	10	8	24	48	1320	1450	

Weights do not include risers or optional valve setter.

Note: Dimensions shown are nominal. Allowances must be made for normal manufacturing tolerances.

American Backflow Specialties

www.americanbackflow.com

(800) 66-BKFLO

(619) 527-2525

Fax: (619) 527-2527

Model 870 / 870V Parts

ITEM	DESCRIPTION	MATERIALS
1	Body	A536 GR 65-45-12
2	Cover	A536 GR 65-45-12
2.1	O-ring	EPDM ASTM D2000
2.2	Cap Screw	Plated Steel
2.3	Hex Nut	Plated Steel
2.5	Cover (w/o holes)	A536 GR 65-45-12
3	Seat Ring	B524 Alloy C83600
3.1	Gasket	EPDM ASTM D2000
4	Arm	B584 Alloy C83600
4.1	Bushing-Swing Pin	Acetal Resin
4.2	Swing Pin	304 SS
5	Retaining Clip	302 SS
5.1	Retaining Clip	302 SS
6	Check Disk (2-1/2" - 8")	EPDM Coated GR, 45 Ductile Iron w/ type 304 SS
	Seat Disc (10" Only)	Silicone ASTM D2000
6.1*	Disc Holder (10" Only)	ASTM A743 304 SS
6.2*	Disc Retainer (10" Only)	ASTM A743 304 SS
6.3*	Capscrew (10" Only)	18-8 SS
7	Load Pin	304SS
8	Lower Spring Retainer	B584 Alloy C83600
9	Spring Stem	304SS
9.1	Elastic Stop Jam Nut	18-8 SS
10	Spring	A313 Type 631 SS
10.2	Spring Shim	Acetal Resin
10.3	Spring Shim	Acetal Resin
11	Spring Guide	B130 Alloy C22000
12	Upper Spring Retainer	B584 Alloy C83600
12.1	Bushing Spring Stem	Acetal Resin
13	Pivot Bearing	B585 Alloy C83600
14	Flange Gasket	Rubber/Fabric
15	Bearing Socket	Acetal Resin
16	Hex Jam Nut	18-8 SS
	Capscrew (10" Only)	18-8 SS
17	Washer	302 SS
18	Flange Nut	Plated Steel
18.1	Flange Nut	Plated Steel
19	Cover	A36 Stl. Epoxy Coated
24	Bolt	Plated Steel
24.1	Washer	Plated Steel
25	Bolt	Plated Steel
26	Gasket	EPDM ASTM D2000
35	O-ring	EPDM ASTM D1999
35.1	Back Up Ring	Acetal Resin
36	Cover	B584 Alloy C83600
40	Ball Valve	B584 Alloy C83600
41	Nipple	Brass
42	Gate Valve (OS&Y)	AWWA C509
43	Bulkhead Fitting	B584 Alloy C83600
43.1	Bulkhead Fitting	B584 Alloy C83600
44	Bulkhead Fitting	B584 Alloy C83600
45	Gasket	EPDM ASTM D2000
45.1	Gasket	EPDM ASTM D2001
46	Washer	B36 Alloy 260
46.1	Washer	B36 Alloy 260
47	Nut	B584 Alloy C83601
47.1	Nut	B584 Alloy C83602
60	Identification Plate	B36 Alloy C26000
61	Identification Plate	B36 Alloy C26000
62	Drive Screw	Stainless Steel
70	Clamp 876V Only	AWWA C606

* Not Shown

Flow Curves

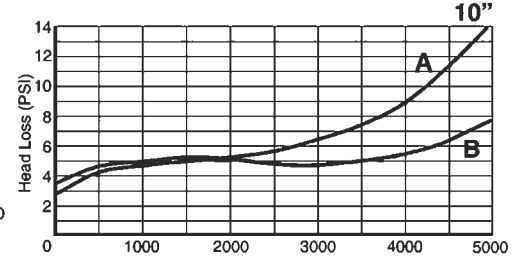
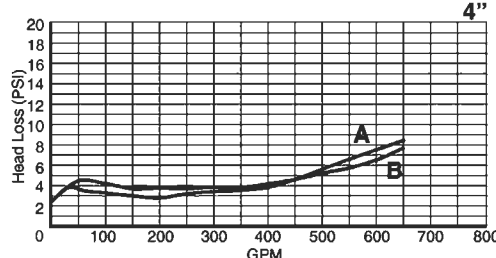
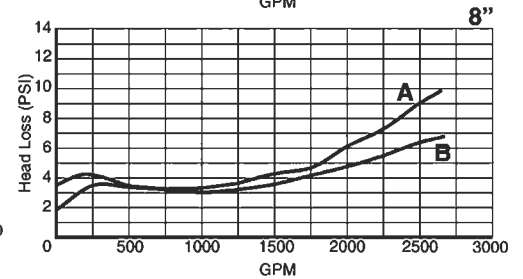
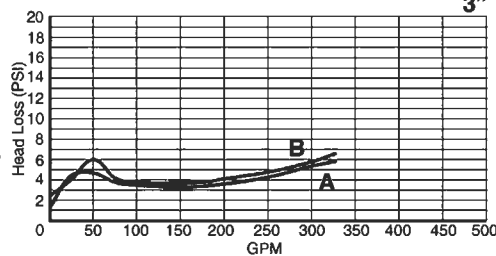
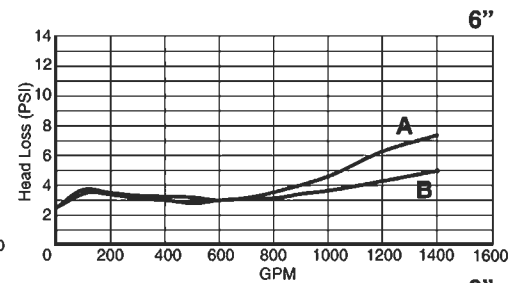
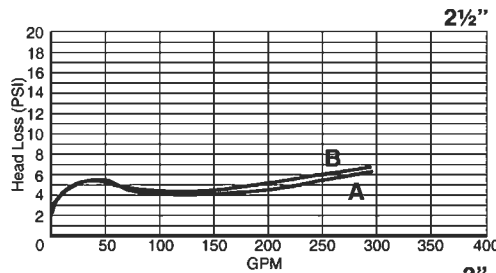

A-Vertical orientation (model 870V)
B-Standard orientation (model 870 and 870V)

Flow Orientation

Standard orientation is inlet flow vertical up, outlet flow vertical down.
Vertical orientation is inlet and outlet flow vertical up.



KIT DESCRIPTION	2-1/2"	3"	4"	6"	8"	10"
Check Replacement Kit (items 2.1, 3, 3.1, 3.2, 3.4, 4, 4.1, 4.2, 5, 5.1, 6, 7, 8, 9, 9.1, 10, 11, 12, 12.1, 13, 15, 16, 17)	850 870(V) 856 876(V)	905-527 905-528 905-529 905-530	905-527 905-528 905-529 905-530	905-534 905-534 905-536 905-536	905-537 905-537 905-538 905-538	905-539 905-539 905-541 905-541
856/876 DCDA Inlet Spring Module (items 5.1, 7, 8, 9, 9.1, 10, 10.2, 11, 12, 12.1) (8" - item 10.3)		905-147	905-147	905-148	905-149	905-150 (856) 905-151 (876)
856/876 DCDA Outlet Spring Module (items 5.1, 7, 8, 9, 9.1, 10, 10.2, 10.3, 11, 12, 12.1) (8" - item 10.3)		905-147	905-147	905-148	905-149	905-150 (856) 905-151 (876)
870/876 Disc Assembly (items 6, 16, 17)		905-152	905-152	905-153	905-154	905-155 400-145
Seat Ring / Arm Assembly (items 3, 3.1, 3.2, 3.4, 4, 4.1, 4.2, 5)		905-157	905-157	905-158	905-159	905-160 (850/856) 905-161 (870/876)
870/876 Rubber Kit (items 2.1, 3.1, 6, 15, 26, 35, 35.1, 45, 45.1)		905-162	905-162	905-163	905-164	905-165 905-166
870(V)/876(V) Cover Assembly Outlet Check only (items 2.1, 2.5, 15)		905-244	905-244	905-245	905-246	905-247 905-248
Bulkhead Fittings Assembly Cover (items 43.1, 45.1, 46.1, 47.1)		905-275	905-275	905-275	-	-
Bulkhead Fittings Assembly Cover (items 43, 45, 46, 47)		905-276	905-276	905-276	-	-
Bulkhead Fittings Assembly Body & Cover (items 43, 45, 46, 47)		905-277*	905-277*	905-277*	905-277	905-277 905-277
Bulkhead Plug Assembly 2nd Check Cover (N & V Units) Early Prod. (items 44, 45.1, 46.1, 47.1)		905-278	905-278	905-278	-	-
Bulkhead Plug Assembly 2nd Check Cover (N & V Units) Early Prod. (items 44, 45, 46, 47)		-	-	-	905-279	905-279 905-279