

Model AGD-Y/AGD-L (3/4"-10") Air Gap Drain

Features

- Reduces amount of water splashing in area around reduced pressure assemblies.
- Funnels minor relief valve discharge into drain.
- Conforms to air gap installation requirements.

Operation

The air gap drain is designed to be installed under the 825Y 3/4"-2" and 825YD 2 1/2"-10" reduced pressure assemblies to catch minor relief valve discharge due to pressure fluctuations and/or minor check valve fouling.

NOTE: The air gap drain is not designed to catch the maximum flows possible from the devices. Water line pressure, size and length of drain piping limits the amount of water handled by the AGD system.

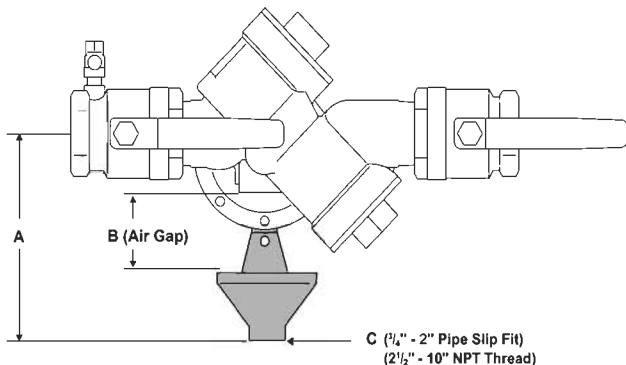

Dimensions & Weights

Size	A	B	C	Wt.	
3/4", 1", & 1 1/4"	6 1/2"	2"	1" Pipe	.12 lbs	AGD-Y
1 1/2" & 2"	7 1/2"	2 3/4"	1" Pipe	.12 lbs	
2 1/2"	12 1/4"	5 3/4"	2" NPT	7 lbs.	AGD-L
3"	12 1/2"	5 3/4"	2" NPT	7 lbs.	
4"	12 3/4"	5 3/4"	2" NPT	7 lbs.	
6"	13"	5 3/4"	2" NPT	7 lbs.	
8"	13 1/2"	5 3/4"	2" NPT	7 lbs.	
10"	13 3/4"	5 3/4"	2" NPT	7 lbs.	

Specifications

The air gap drain shall be corrosion resistant material with stainless steel mounting fasteners. The drain must be of a design that allows mounting by attachment of the drain to the relief valve of a reduced pressure assembly.

The air gap drain shall be FEBCO Model AGD or prior approved equal.

NOTE: Consult local codes to insure drain installation meets all requirements.

Materials

Corrosion resistant funnel and stainless steel mounting fasteners.

Installation Instructions

1. Before installation check local codes. This type of drain may not be approved for use in some areas.

CAUTION: This drain is intended to catch minor relief valve discharges.

Under certain conditions relief valves can discharge water at rates significantly greater than the drain capacity.

2. After installation of RP device and piping, attach drain funnel onto pipe. Do not use the RP device to support the drain pipe weight.

3. SIZES: 3/4", 1", & 1 1/4": Attach funnel with the shorter bolt by threading through the funnel into the tapped hole in the relief valve body.

SIZES: 1 1/2" and 2": Replace the lower cover bolt with the supplied long (relieve all pressure in the device before removing the cover bolt). Attach spacer to funnel using smaller bolt and nut. Position funnel/spacer over the protruding bolt end and secure with the supplied nut.