

SPECIFICATION SUBMITTAL SHEET



FEATURES

Sizes: 3/4" 1"

Maximum working water pressure 175 PSI
 Maximum working water temperature 140°F
 Hydrostatic test pressure 350 PSI
 Threaded connections ANSI B1.20.1

Integral anti-freeze relief valve
 Replaceable thermoplastic modular cartridge

OPTIONS

(Suffixes can be combined)

- with full port QT ball valves (standard)

ACCESSORIES

- Repair kit (complete)
- Repair kit (rubber only)
- Repair kit (freeze kit)
- Water hammer arrester (Model 1250)

APPLICATION

Designed for installation on potable water lines to protect against backsiphonage of contaminated water into the potable water supply. Supplied with an integral anti-freeze relief valve to reduce the risk of valve damage under intermittent, non-seasonal freezing conditions. Designed for use under continuous pressure. Assembly shall provide protection where a potential health hazard exists.

STANDARDS COMPLIANCE

- ASSE® Listed 1020
- IAPMO® Listed
- CSA® Certified
- Approved by the Foundation for Cross Connection Control and Hydraulic Research at the University of Southern California

MATERIALS

Main valve body Cast Bronze ASTM B 584
 Elastomers Silicone (FDA Approved)
 Buna Nitrile (NSF Listed)
 Polymers Polypropylene (FDA Approved)
 Delrin™ (NSF Listed)
 Noryl™ (NSF Listed)
 Springs Stainless Steel, 300 Series

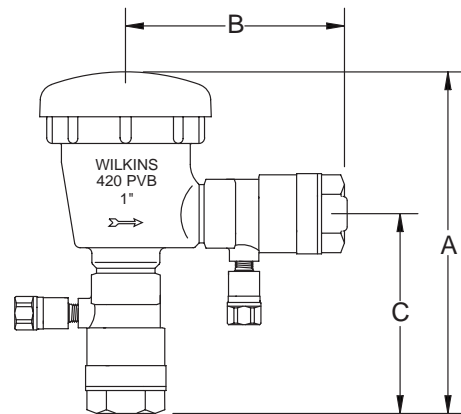

DIMENSIONS & WEIGHTS (do not include pkg.)

MODEL SIZE		DIMENSIONS (approximate)						WEIGHT	
		A		B		C			
in.	mm	in.	mm	in.	mm	in.	mm	lbs.	kg
3/4	20	6 3/4	172	4 1/4	108	3 13/16	97	4	1.8
1	25	7 15/16	202	4 15/16	125	4 1/2	114	5	2.3

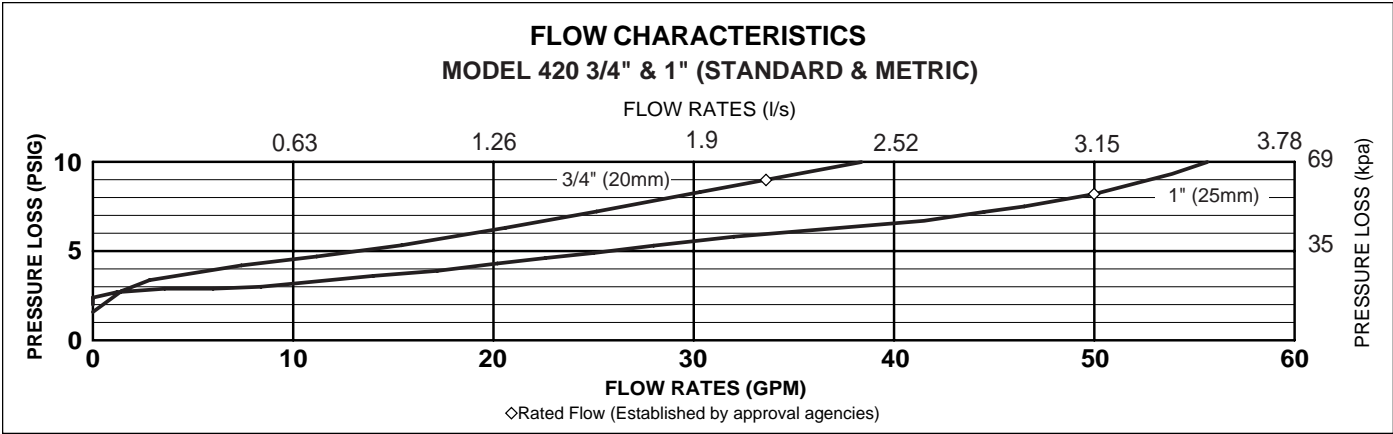

TYPICAL INSTALLATION

Local codes shall govern installation requirements. Unless otherwise specified, the assembly shall be installed in accordance with the manufacturers' instructions and the latest edition of the Uniform Plumbing Code. The assembly shall be mounted at a minimum of 12" (305mm) above the highest piping or outlet downstream of the device. Install with adequate drain and sufficient side clearance for testing and maintenance. The installation shall be made so that no part of the unit can be submerged. A pressure vacuum breaker cannot be installed where back-pressure could occur or where spillage of water from vent could cause damage.

Capacity thru Schedule 40 Pipe				
Pipe size	5 ft/sec	7.5 ft/sec	10 ft/sec	15 ft/sec
1/8"	1	1	2	3
1/4"	2	2	3	5
3/8"	3	4	6	9
1/2"	5	7	9	14
3/4"	8	12	17	25
1"	13	20	27	40
1 1/4"	23	35	47	70
1 1/2"	32	48	63	95
2"	52	78	105	167

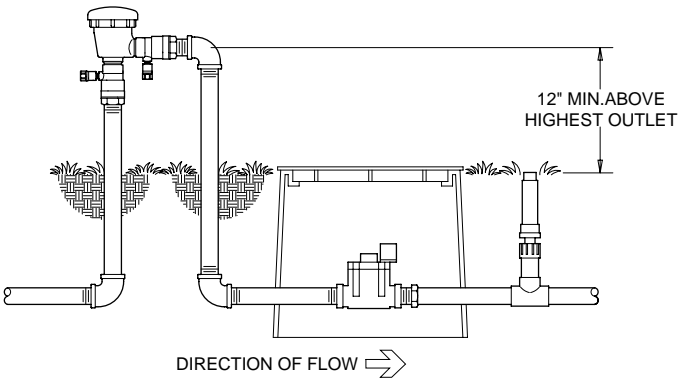

OUTDOOR INSTALLATION

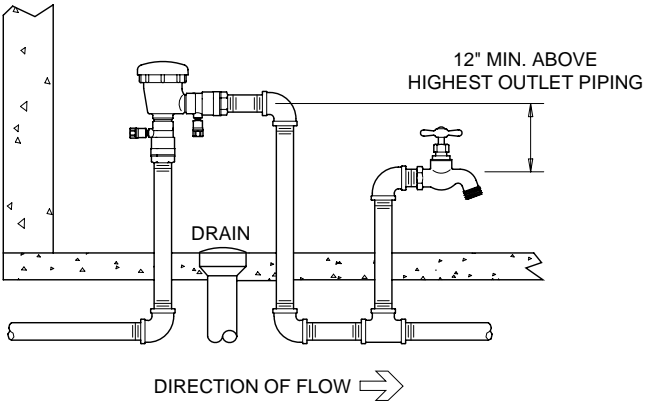

INDOOR INSTALLATION

SPECIFICATIONS

The Pressure Vacuum Breaker shall be ASSE® Listed 1020, and supplied with full port ball valves. The main body shall be bronze (ASTM B 584), the loaded-air inlet shall use a silicone elastomer spring and seat disc. The assembly shall include an integral relief valve. The entire assembly shall be accessible for maintenance and testing without removing the device from the line. The Pressure Vacuum Breaker shall be a WILKINS Model 420.